

INSTALLATION DETAILS FOR VLA-300 LIGHTNING ARRESTER

SUGGESTED GAP SETTINGS	
DIELECTRIC STRENGTH OF DRY AIR IS APPROXIMATELY 3000 KV/M	
300 KV	3.9 IN (10.0 CM)
200 KV	2.6 IN (6.7 CM)
100 KV	1.3 IN (3.3 CM)
50 KV	0.6 IN (1.7 CM)

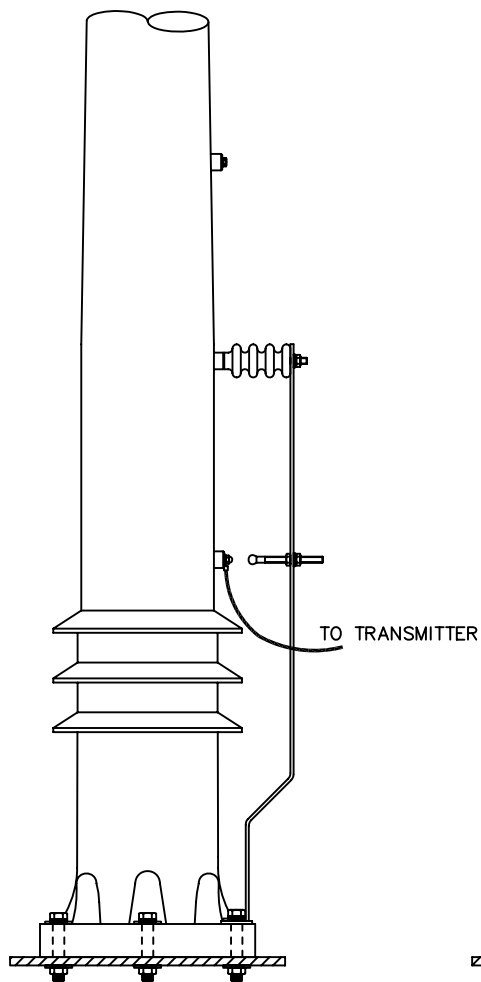

FEEDPOINT 1 CONFIGURATION

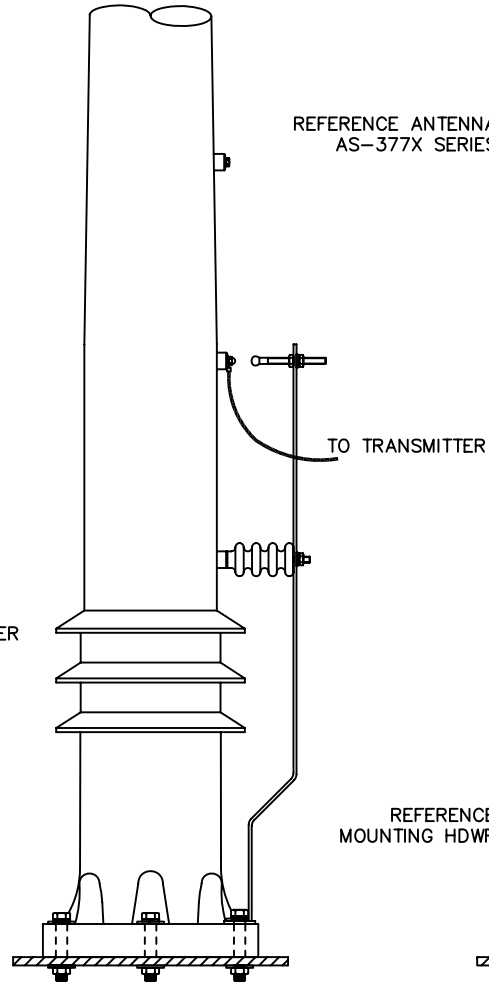

FEEDPOINT 2 CONFIGURATION

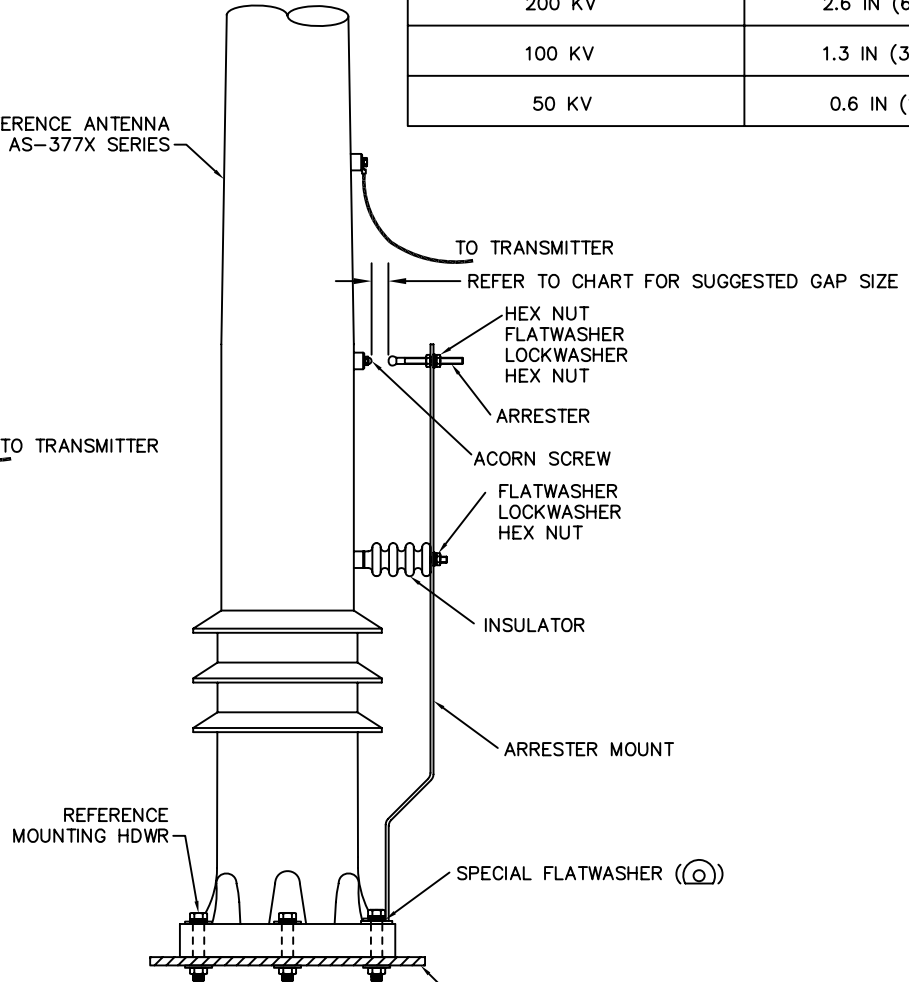

FEEDPOINT 3 CONFIGURATION

REFERENCE MOUNTING PLATE
(CONNECTED TO GROUND)