



**TECHNICAL MANUAL**

**VTM-07-007**

**OPERATION AND INSTALLATION  
INSTRUCTIONS**

**AS-3226C/URC  
VHF ANTENNA**

**REVISION SHEET**

<b>Revision</b>	<b>Description</b>	<b>Date</b>
-	- Original Issue -	November 13, 2007

Errors in this publication can be reported to the Manufacturer.  
Refer to Section 6 for contact information and address  
attention to the Engineering Department.

**Valcom Manufacturing Group, Inc.**

175 Southgate Drive, P.O. Box 603, Guelph, Ontario, Canada N1H 6L3 Tel: 519-824-3220 Fax: 519-824-3411  
Web Site: [www.valcom-guelph.com](http://www.valcom-guelph.com) E-mail: [enquiries@valcom-guelph.com](mailto:enquiries@valcom-guelph.com)

---

**TABLE OF CONTENTS**

<b><u>Section</u></b>	<b><u>Page</u></b>
<b>1 GENERAL INFORMATION AND SAFETY PRECAUTIONS .....</b>	<b>1</b>
1-1 Safety Precautions .....	1
1-2 Introduction .....	1
1-3 Equipment Description .....	1
1-4 Relationship to Other Equipment .....	1
1-5 Reference Data .....	1
1-6 Equipment and Documents Supplied .....	1
1-7 Equipment and Publications Required But Not Supplied .....	1
<b>2 OPERATION .....</b>	<b>5</b>
2-1 General .....	5
<b>3 FUNCTIONAL DESCRIPTION .....</b>	<b>6</b>
3-1 Functional Description .....	6
a. Electrical Balance .....	6
b. Radiation Patterns .....	6
<b>4 SCHEDULED MAINTENANCE .....</b>	<b>7</b>
4-1 Introduction .....	7
4-2 Scheduled Maintenance Action Index .....	7
4-3 Preventive Maintenance Procedures .....	7
4-4 Scheduled Performance Tests .....	8
a. Safety Precautions .....	8
b. Tools and Test Equipment .....	8
c. Title of Test .....	8
d. Minimum Rating of Technician .....	8
e. VSWR Test Setup .....	8
f. Procedures .....	9
g. Test Values .....	9
h. Corrective Actions .....	9
<b>5 TROUBLESHOOTING .....</b>	<b>10</b>
5-1 Introduction .....	10
5-2 Troubleshooting Index .....	10
5-3 Maintenance Turn-On Procedures .....	10
5-4 Troubleshooting Procedures .....	10
<b>6 CORRECTIVE MAINTENANCE .....</b>	<b>12</b>

6-1	Introduction .....	12
6-2	Adjustments and Alignment .....	12
6-3	Repair .....	12
<b>7</b>	<b>PARTS LIST .....</b>	<b>13</b>
7-1	Introduction .....	13
a.	List of Parts .....	13
b.	List of Manufacturers .....	13
<b>8</b>	<b>INSTALLATION .....</b>	<b>14</b>
8-1	Site Information .....	14
8-2	Tools and Materials Required .....	14
8-3	Unpacking and Repacking .....	14
8-4	Foundation .....	14
8-5	Input Requirements .....	14
8-6	Installation Procedures .....	14
8-7	Installation Checkout .....	14

### LIST OF FIGURES

Figure		Page
1-1	VHF Antenna AS-3226C/URC .....	2
3-1	Balancing Transformer Arrangement .....	6
4-1	VSWR Test Setup .....	9
8-1	Installation Data .....	15

### LIST OF TABLES

Table		Page
1-1	Reference Data .....	3
1-2	Equipment and Documents Supplied .....	3
1-3	Equipment and Publications Required But Not Supplied .....	4
1-4	Field and Factory Changes .....	4
4-1	Scheduled Maintenance Action Index .....	8
5-1	Troubleshooting Index .....	10
5-2	Troubleshooting Procedures .....	11
7-1	List of Parts .....	13
7-2	List of Manufacturers .....	13

**SECTION 1**  
**GENERAL INFORMATION AND SAFETY PRECAUTIONS**

**1-1. SAFETY PRECAUTIONS.** When working in the vicinity of VHF Antenna AS-3226C/URC, make sure the antenna is de-energized in accordance with the WARNING in paragraphs 4-3 and 4-4, and when testing the antenna, make sure the test equipment is properly grounded in accordance with WARNING in paragraph 4-4.

**1-2. INTRODUCTION.** This manual provides general information, operating and functional descriptions, maintenance and troubleshooting instructions, parts list data, and installation data for VHF Antenna AS-3226C/URC.

**1-3. EQUIPMENT DESCRIPTION.** The AS-3226C/URC VHF Antenna (see figure 1-1) is a general purpose, high performance, reliable, vertically polarized, broadband dipole covering the 30 to 108 MHz frequency range. It is designed for use under the severe environmental conditions encountered aboard naval vessels. It is used for either receiving or transmitting Very High Frequency signals. The antenna is a base-mounted light-weight, single piece fiberglass vertical dipole.

**1-4. RELATIONSHIP TO OTHER EQUIPMENT.** The AS-3226C/URC VHF Antenna interfaces with the ship's VHF receiving and transmitting equipment.

**1-5. REFERENCE DATA.** Table 1-1 lists the reference data for the antenna.

**1-6. EQUIPMENT AND DOCUMENTS SUPPLIED.** Table 1-2 lists the equipment and documents supplied.

**1-7. EQUIPMENT AND PUBLICATIONS REQUIRED BUT NOT SUPPLIED.** Table 1-3 lists the equipment and publications required but not supplied.

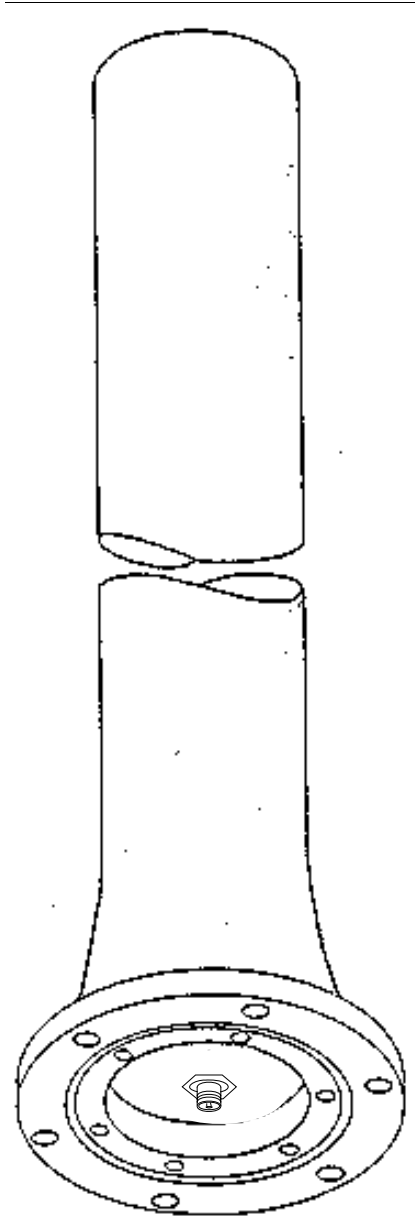

**Figure 1-1** VHF Antenna AS-3226C/URC

**Table 1-1. Reference Data**

<b>Parameter</b>	<b>Specification</b>
Nomenclature	Antenna AS-3226CB/URC
Manufacturer	Valcom Mgf Grp, Inc 35736
Frequency Range	30 to 108 MHz
Impedance	50 ohms
VSWR	less than 3.0:1
Polarization	Vertical
Power Capability	1000 watts
Gain	0 dBi (nominal)
Radiation Pattern	Horizontal - omnidirectional Vertical - figure 8
Temperature	Operating: -54°C to +65°C Non Operating: -62°C to +71°C
Wind Velocity	120 mph
Humidity	95%
Shock	Qualified to meet MIL-S-901C, Grade A
Vibration	Qualified to meet MIL-STD-167, Type I

**Table 1-2. Equipment and Documents Supplied**

<b>Qty</b>	<b>Nomenclature</b>	<b>Overall Dimensions (inches)</b>				<b>Weight Uncrated</b>
		<b>Crated</b>		<b>Uncrated</b>		
		<b>Length</b>	<b>Width (sq)</b>	<b>Height</b>	<b>Diameter</b>	
1	VHF Antenna AS-3226C/URC	156	18	149	4.25	47 lbs
1	Technical Manual VTM-07-00?	--	--	--	--	--

**Table 1-3. Equipment and Publications Required But Not Supplied**

Category	Recommended Equipment	Alternate	Test Parameter	Application
Power Supply	General Radio Type 1203-B	Hewlett Packard Generator Model 608E	VSWR equal to or less than 3.0:1	Scheduled maintenance and trouble-shooting
Modulating Source	General Radio Type 1214-A			
VHF Generator	General Radio Type 1211-C and Type 1215-C			
Impedance Bridge	PRD Electronic Type 3302	--		
Standing Wave Indicator	HP Model 415B	General Radio Type 1234		
Electronic Counter	HP Type 5246L	HP Type 5340A		
Megohmmeter	Freed Type 1620	--	Insulation Resistance greater than 1 megohm	Trouble-shooting

Table 1-4. Field and Factory Changes

Change Number	Nomenclature	Description
None	--	--

**SECTION 2  
OPERATION**

**2-1. GENERAL.** The AS-3226C/URC Antenna has no operating controls or indicators. It operates only when the ship's VHF receiving and transmitting equipment is operated.

### SECTION 3 FUNCTIONAL DESCRIPTION

**3-1. FUNCTIONAL DESCRIPTION.** The AS-3226C/URC VHF Antenna is a general purpose, high performance, vertically polarized, broadband, balanced dipole covering the 30 to 108 MHz frequency range. It is used for either transmitting or receiving. The antenna is a cylindrical dipole radiator fed by a conventional coaxial RF line. Integrated into the antenna structure is a balancing transformer arrangement, which allows the dipole radiator to be fed in a balanced manner eliminating extraneous line currents. (see figure 3-1).

- a. Electrical Balance. The electrical balance provided for the radiating elements permits feeding the antenna directly by 50 ohm coaxial cable. The input VSWR is less than 3.0:1 on 50 ohms.
- b. Radiation Patterns. Radiation patterns for the antenna correspond to those of a balanced dipole in free space. Coverage in the plane perpendicular to the radiating elements is omnidirectional. Figure 8 coverage, with nulls off the ends of the elements, is provided in the plane of the radiators. The inherent broadband impedance characteristics make the antenna relatively insensitive to its mounting environment and minimize azimuth and zenith pattern distortion at any location.

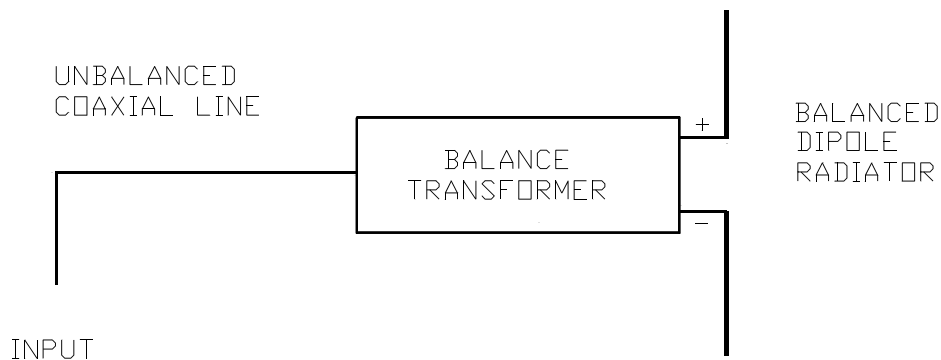

**Figure 3-1** Balancing Transformer Arrangement

---

## SECTION 4 SCHEDULED MAINTENANCE

**4-1. INTRODUCTION.** This section provides preventative maintenance procedures and scheduled performance tests to be accomplished on a regularly scheduled basis. These procedures, performed as scheduled, will significantly reduce downtime for corrective maintenance. The arrangement of the material in this section is a scheduled maintenance action index with supporting test. The scheduled maintenance instructions in this manual are cancelled when the Planned Maintenance System (PMS) is implemented for this equipment aboard your ship or station.

**4-2. SCHEDULED MAINTENANCE ACTION INDEX.** Table 4-1 lists preventive maintenance procedures and scheduled performance tests.

**4-3. PREVENTATIVE MAINTENANCE PROCEDURES.** The following procedures included the information required for the antenna preventive maintenance:

<b>WARNING</b>
----------------

**The antenna operates at 1000 watts. Ensure that the transmitting equipment is de-energized prior to performing the preventive maintenance procedure.**

- b. Visually inspect the antenna for dirt. Wash dirt off the antenna with soap and water. A technician with a minimum rating of ETN3 can perform the task.
  
- b. Visually check painted surfaces for wear, chipping, etc. Paint the antenna with grey epoxy enamel (MIL-P-24441). A technician with a minimum rating of ETN3 can perform this task.

**4-4. SCHEDULED PERFORMANCE TESTS.** The following procedures include the information required for checking the VSWR:

<b>WARNING</b>
----------------

**The antenna operates at 1000 watts. Ensure that the transmitting equipment is de-energized when performing the following test. Also make sure the test equipment is grounded.**

- a. Safety Precautions. Be sure the transmitting equipment is deenergized and the test equipment is properly grounded.

**Table 4-1. Scheduled Maintenance Action Index**

Periodicity	Maintenance Action	Reference
A	Inspect antenna for dirt	4-3.a
A	Check painted surfaces for wear, chipping, etc.	4-3.b
A	Check the VSWR of the antenna	4-4

- b. Tools and Test Equipment. No tools are required. The power supply, modulating source, VHF generator, impedance bridge, standing wave indicator and electronic counter in table 1-3 are used for this check.
- c. Title of Test. The title of the test to be performed is VSWR Test.
- d. Minimum Rating of Technician. A technician with a minimum rating of ETN3 can perform this task.
- e. VSWR Test Setup. Figure 4-1 shows the VSWR test setup for the antenna.

f. Procedures.

- (1) Prepare test setup as shown in figure 4-1.
- (2) At 10 MHz intervals between 30 MHz and 100 MHz, inclusive, plus 108 MHz, perform the following steps.
  - (a) Tune VHF generator to desired frequency as indicated on electronic counter.
  - (b) Tune impedance bridge for maximum reading as indicated on standing wave indicator.
  - (c) Set reference level on standing wave indicator to 1.0 on SWR scale.
  - (d) Tune impedance bridge for minimum reading as indicated by standing wave indicator.
  - (e) Read VSWR on standing wave indicator on SWR scale.

g. Test Values. If VSWR is 3.0:1 or greater, internal damage is indicated.

h. Corrective Action. Refer to table 5-3 for corrective actions.

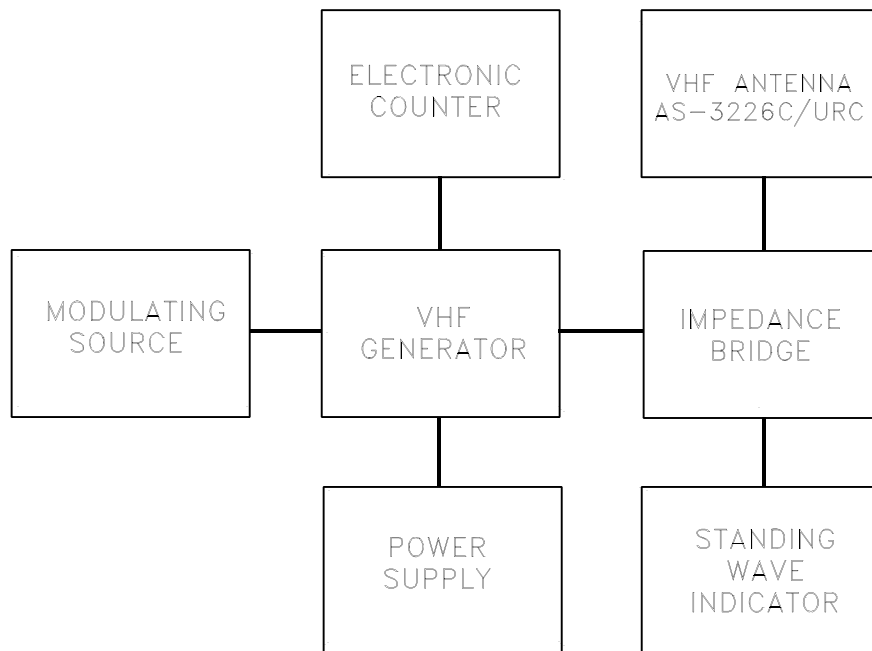

**Figure 4-1** VSWR Test Setup

## SECTION 5 TROUBLESHOOTING

**5-1. INTRODUCTION.** Transmission trouble in the receiving or transmitting system of which the AS-3226C/URC VHF Antenna is a part may be caused by trouble in the antenna, in another piece of equipment, or in the transmission line. If trouble occurs, check to determine that the equipment and the RF transmission line being used with the antenna are functioning properly before attempting to follow the procedures described in this section. The antenna is essentially a sealed assembly and as such is non repairable.

**5-2. TROUBLESHOOTING INDEX.** Table 5-1 lists possible troubles with references to the appropriate procedures in this section.

**5-3. MAINTENANCE TURN-ON PROCEDURE.** The AS-3226C/URC VHF Antenna is turned on when the ship's VHF receiving and transmitting equipment is turned on.

**5-4. TROUBLESHOOTING PROCEDURES.** Table 5-2 is a troubleshooting procedures table.

**Table 5-1. Troubleshooting Index**

Functional Area	Troubleshooting Paragraph	Troubleshooting Diagram	Functional Description Paragraph	Alignment Adjust Paragraph
Subnormal antenna operation	5-4	--	3-1	6-2

**Table 5-2. Troubleshooting Procedures**

SYMPTOM	PROBABLE CAUSE	CORRECTIVE ACTION
Low insulation resistance (less than one megohm as indicated by megohmmeter connected between inner and outer conductors of RF connector)	<ol style="list-style-type: none"> <li>1. Defective RF connector or RF gasket.</li> <li>2. Defective internal assembly in antenna.</li> </ol>	Replace antenna.
High VSWR (greater than 3.0:1) as indicated by VSWR test described in paragraph 4-4.	<ol style="list-style-type: none"> <li>1. Defective RF connector or RF gasket.</li> <li>2. Defective internal assembly in antenna.</li> </ol>	Replace antenna.

**SECTION 6**  
**CORRECTIVE MAINTENANCE**

**6-1. INTRODUCTION.** No corrective maintenance can be performed on the AS-3226C/URC VHF Antenna.

**6-2. ADJUSTMENTS AND ALIGNMENT.** No adjustments and alignment are applicable to the antenna.

**6-3. REPAIR.** No repair of the antenna or any of its parts is applicable.

## SECTION 7 PARTS LIST

**7-1. INTRODUCTION.** The parts list for the antenna identifies all shipboard, tender, and shore-based repair parts including attaching hardware. The parts list is arranged in two tables as follows:

Table 7-1. List of Parts

Table 7-2. List of Manufacturers

- a. List of Parts. Table 7-1 lists the parts of the AS-3226C/URC Antenna as shipped.
- b. List of Manufacturers. Table 7-2 contains the name, address, and Federal Supply Code for Manufacturers of the manufacturers supply items for the equipment as referenced in Table 7-1.

**Table 7-1. List of Major Units**

UNIT NUMBER	NOMENCLATURE		
	Name of Unit	Designation	Page Number
1	VHF Antenna	AS-3226C/URC	7-1

**Table 7-3. List of Manufacturers**

<b>Valcom Manufacturing Group, Inc</b>		<b>Code : 35736</b>
<b>Postal address:</b>	<b>Shipping address:</b>	
Valcom Manufacturing Group, Inc P.O. Box 603 Guelph, Ontario Canada N1H 6L3	Valcom Manufacturing Group, Inc 175 Southgate Drive Hanlon Industrial Park Guelph, Ontario Canada N1G 3M5	

## SECTION 8 INSTALLATION

**8-1. SITE INFORMATION.** The AS-3226C/URC VHF Antenna is designed primarily for shipboard installation. The antenna can also be used at shore installations. The antenna should be installed in a non-obstructed environment, preferably more than 30 feet from any contiguous structures, such as masts, bulkheads, or other metal objects.

**8-2. TOOLS AND MATERIALS REQUIRED.** No special tools and materials are required for installation.

**8-3. UNPACKING AND REPACKING.** Table 1-2 gives data on the overall dimensions, volume, and weight of the crated antenna. To unpack, carefully pry off the cover, and remove the antenna from the container. Save the container to pack the antenna for reshipment. No special handling procedures are required; observe normal precautions when handling the antenna.

**8-4. FOUNDATION.** The antenna should be installed vertically on a mounting plate that has bolt holes matching those in the antenna base (see Figure 8-1). The mounting plate must have a center hole to accommodate the transmission line to the antenna.

**8-5. INPUT REQUIREMENTS.** The antenna has an RF power handling capability of 1000 watts in the 30 to 108 MHz frequency range.

**8-6. INSTALLATION PROCEDURES.** After unpacking the antenna, proceed with its installation as follows:

- a. Examine the exterior of the antenna for damage; make sure that the RF connector is not deformed, misaligned, or fractured.
- b. Perform an insulation resistance test in accordance with step 1 of Table 5-2.
- c. Check the voltage standing wave ratio in accordance with paragraph 4-4.
- d. Place the antenna on its mounting plate. Tilt the antenna to connect the input cable to the RF connector.
- e. Secure the antenna to its mounting plate with six 1/2 in. bolts.

**8-7. INSTALLATION CHECKOUT.** Checkout of the antenna after installation can only be accomplished by operating the ship's receiving and transmitting equipment that is used with the antenna.

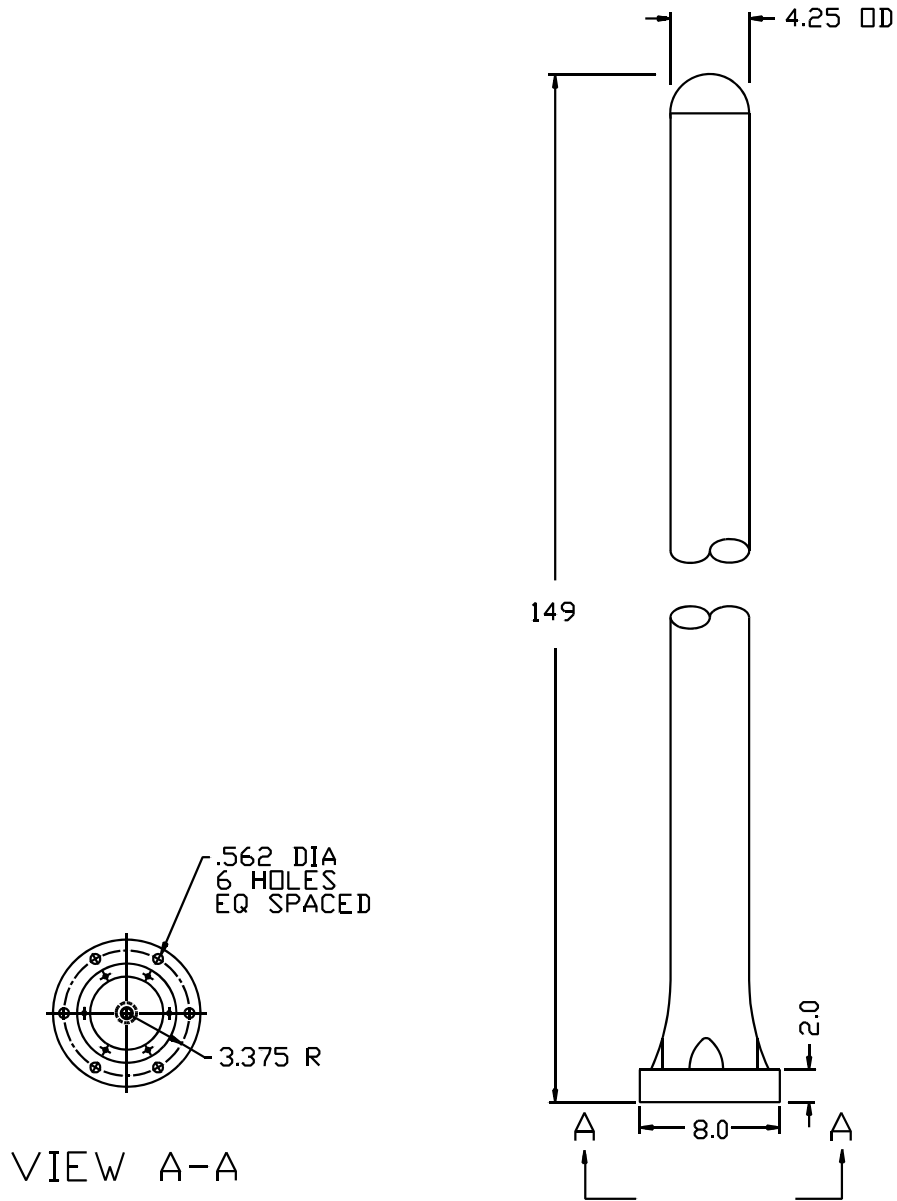

**Figure 8-1** Installation Data of the AS-3226C/URC Antenna